

INSTRUCTION MANUAL

1. GENERAL INTRODUCTION

CH series PID Temperature Controller is the new product developed by our company. It adopts special microcomputer adjusting meter that employs switching power and surface mount technology (SMT), therefore, the controller is quite smart and reliable. Its special functions like auto diagnosing, auto setting and intelligent control. It can be used widely in the display and control of the parameter of the temperature, pressure, flow, and liquid level.

2. MAIN TECHNICAL INDEX

2.1 Input:

Thermocouple(TC),Resistance Temperature Detect (RTD)
Standard Current and voltage signals.

2.2 Display:

Process Value (PV)、 Setting Value(SV):-1999~+1999
Output (OUT1、OUT2) Alarm (ALM1、ALM2) Auto setting(AT)
Display: LED

2.3 Control way

- (1).PID Control(including ON/OFF, position PID and continuous PID)
- (2).Auto Setting Control

2.4 Accuracy

Measurement Accuracy:0.5%FS
Compensation error of cold terminal:2 °C(amend within 0~50°C by soft)
Resolution:14bit. Sampling period:0.5Sec.

2.5 Setting Range:

Setting Value(SV): same range with PV
Proportional Band(P):0~full range(ON/OFF Control when set to 0)
IntegrationTime(I):0~3600Sec(no integral action when set to 0)
Derivative Time(D):0~3600Sec(no derivative action when set to 0)
Proportional Period:1~100Sec
On-off control output hysteretic loop width:1~100°C(or other PV units)

2.6 Control Output

- (1)Currency output: DC 0~10Ma,4~20mA(RL<500Ω)
- (2)Voltage output: DC 0-5V,1-5V(RL>10K)
- (3)Relay output: Contact capacity:250V AC 3A(resistive load)
- (4)Voltage Impulse output:0-12V(applicable for solid state relay SSR)
- (5)Silicon Controlled Rectifier(SCR) output: zero-cross triggering or phase-shift triggering(resistive load)
- (6)Alarming function output: 2 groups output at most,12 modes
Output Contact Capacity:250V AC 3A

2.7 Other Parameters

- (1)Insulation resistance:>50MΩ(500V DC)
- (2)Insulation strength:1500V AC/min
- (3)Power consumption:<10W
- (4)Service environment:0~50°C,30~85RH,no corrosive gas
- (5)Weight:abt.0.5Kg(C900type)

3. OUTLINE MOUNTING BORING

Outline & boring size

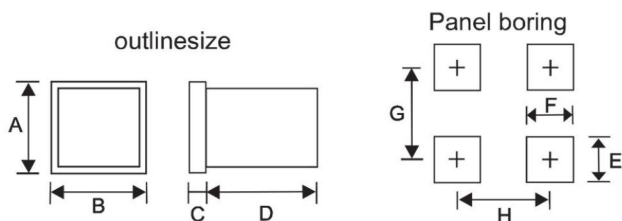

Fig. 1

Form 1

	A	B	C	D	E	F	G	H
CH102	48	48	8	70	45	45	80	80
CH402	96	48	8	70	92	45	116	80
CH502	48	96	8	70	45	92	80	116
CH702	72	72	8	70	68	68	96	96
CH902	96	96	8	70	92	92	116	116

4. PANEL NAME AND FUNCTION



PV: Measured value / mode display value
SV: Setting value/mode display value
AT: PID auto calculation indicator lamp
OUT1: Output 1 indicator lamp
OUT2: Output 2 indicator lamp
ALM1: Alarm 1 indicator lamp
ALM2: Alarm 2 indicator lamp

SET: Setting mode key <R/S: Shift key V: Up key Λ: Down key

5. MODEL DESCRIPTION AND MODEL SELECTION

CH - □ □ □ □ - □ * □ □
① ② ③ ④ ⑤ ⑦ ⑧

E.g.: CH102 - F K 02 - M * A N

- ① Outline size(See Form 1)
- ② Control type
F:PID operation and auto calculation(Reverse operation)
D:PID operation and auto calculation(Forward operation)
- ③ Input type: refer to the Input Range Table (See Form2)
- ④ Range Code: refer to the Input Range Table (See Form2)
- ⑤ First Control Output(OUT1)(Heating side)
M: Relay contact output 8:Current output(DC 4~20mA)
V: Voltage impulse output (SSR)
T: Hydration driving output
- ⑦ First Alarm(ALM1) ⑧ Second Alarm(ALM2)
N: No alarm
A: Upper-Limit bias alarm
B: Lower-Limit bias alarm
C: Upper/Lower Limit bias alarm
D: Alarm in area
E: Standby upper-limit bias alarm attached
F: Standby lower-limit bias alarm attached
G: Standby upper/lower limit bias alarm attached
H: Upper-Limit input value alarm
J: Lower-limit input value alarm
K: Standby upper-limit input value alarm attached
L: Standby lower-limit input value alarm attached

Form2: Input Range Table

Input type	Code	Input range	Code	Input range	Code	Input range		
Thermocouple (TC)	K	K01	0-200°C	K02	0-400°C	K03	0-600°C	
		K04	0-800°C	K05	0-1000°C	K06	0-1200°C	
		K07	0-1372°C	K13	0-100°C	K14	0-300°C	
	J	J01	0-200°C	J02	0-400°C	J03	0-600°C	
		J04	0-800°C	J05	0-1000°C	J06	0-1200°C	
	R * 1	R01	0-1600°C	R02	0-1769°C	R03	0-1350°C	
	S * 1	S01	0-1600°C	S02	0-1769°C			
	B * 1	B01	100-1800°C	B02	0-1769°C			
	E	E01	0-800°C	E02	0-1000°C			
	N	N01	0-1200°C	N02	0-1300°C			
	T * 2	T01	-199.9-400°C	T02	-199.9-100°C	T03	-100-200°C	
		T04	0-350°C					
	RTD	PT100	D01	-199.9-649.0°C	D02	-199.9-200.0°C	D03	-100.0-50.0°C
			D04	-100.0-100.0°C	D05	-100.0-200.0°C	D06	0.0-50.0°C
D07			0.0-100.0°C	D08	0.0-200.0°C	D09	0.0-300.0°C	
D10			0.0-500.0°C					
Cu50		P01	-199.9-649.0°C	P02	-199.9-200.0°C	P03	-100.0-50.0°C	
		P04	-100.0-100.0°C	P05	-100.0-200.0°C	P06	0.0-50.0°C	
		P07	0.0-100.0°C	P08	0.0-200.0°C	P09	0.0-300.0°C	
		P10	0.0-500.0°C					
		Voltage Current	0-5V	401	0.0-100.0°C			
			1-5V	601	0.0-100.0°C			
0-20mA	701		0.0-100.0°C					
4-20mA	801		0.0-100.0°C					

* 1, 0-399 °C : Accuracy is not guaranteed.

* 2, -199.9-100 °C : Accuracy is not guaranteed.

6. TERMINAL CONFIGURATION

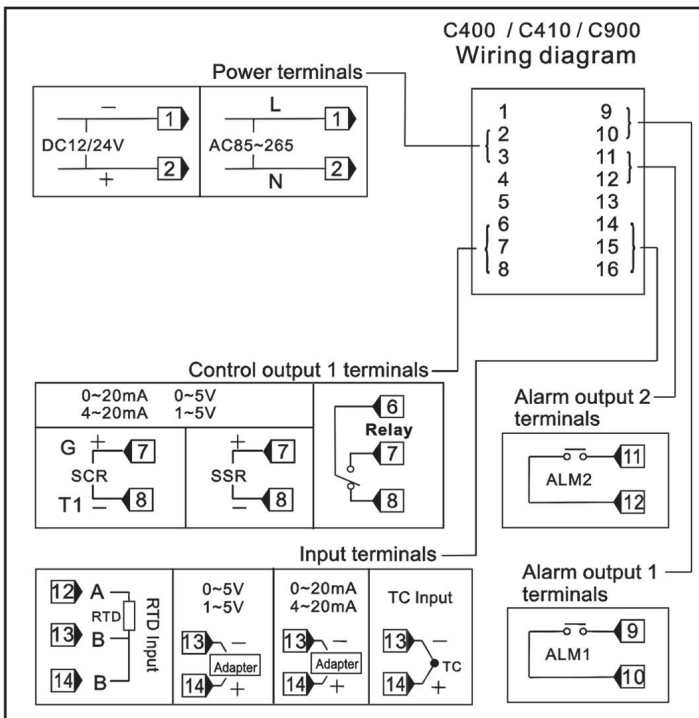
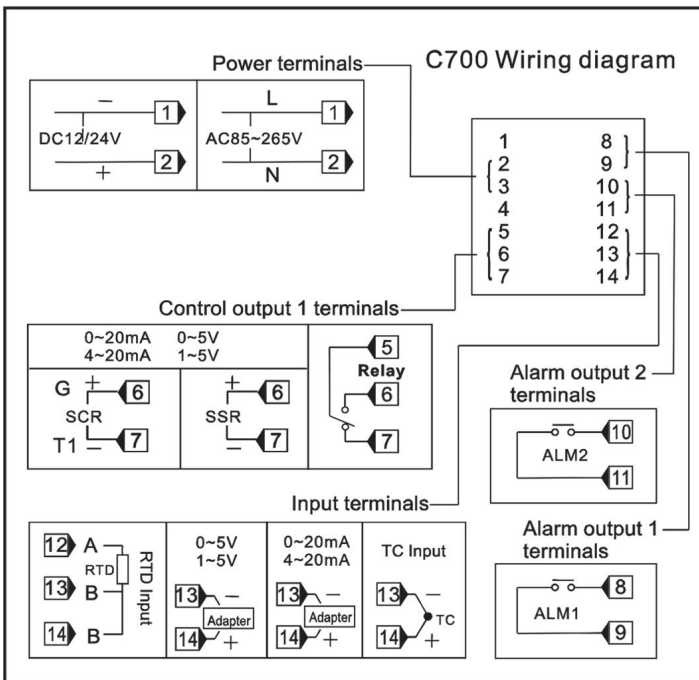
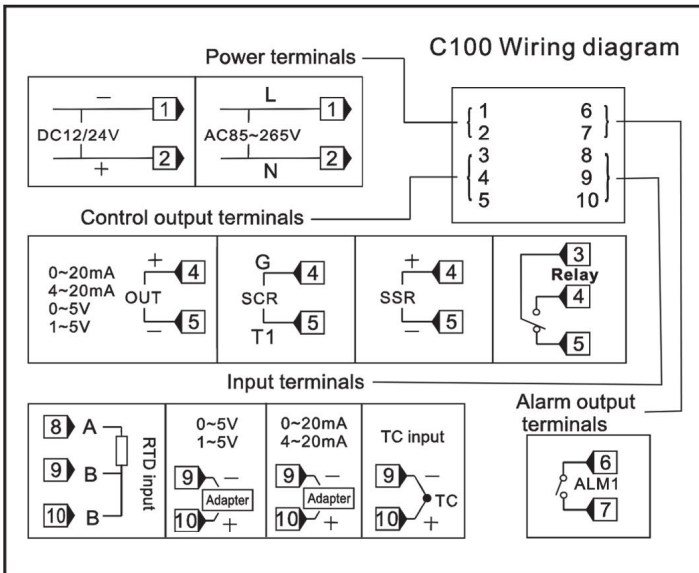

7. OPERATION PROCEDURES

7.1 Procedures of Starting

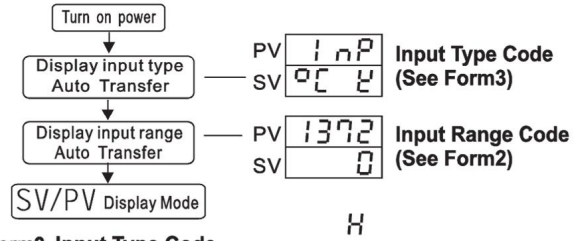

Form3 Input Type Code

Display	U	J	R	S	B	E	N	T	$Pt100$	$Cu50$	oM	mV	mA	v
Input type	Thermocouple(TC)			RTD		Voltage/Current								

Note: When the input signal is current or voltage, you must use our appropriate current & Voltage input adapter

7.2 SV Setting Mode

Under SV/PV normal display state, first, press SET key to make the SV display in the flashing state, second, press the < key to find the place number of required setting temperature, third, press UP or DOWN key to set the required temperature, after ending the setting, press SET key again to let the meter come back to SV/PV normal display state.

7.3 Parameter Setting Mode

This parameter is used to set the alarming parameter, PID constant, etc, under the normal displaying state, press the SET key for three seconds, the PV display will show the parameter setting state, and SV display will show the corresponding value, then, press SET key in turn to display the parameter symbol specified in the following table:

Form4

Display symbol	Description	Setting range	Factory value
PV SV	Measured Value Setting Value	Full range	
$AL1$	Alarm1 setting	Full range	50.0or50
$AL2$	Alarm2 setting	Full range	50.0or50
RFU	Self setting	0:Auto-setting for closing 1:Auto-setting for opening	0
P	Proportional band	ON/OFF control when setting to 0	30 or 30.0
I	Integration time(s)	1-3600sec No derivative action when setting to 0	240
D	Derivative time(s)	1-3600sec No derivative action when setting to 0	60
Rr	Limit integration operation work range	Proportional band 1-100%	25
f	Working cycle (s)	1-100sec NO display when current outputs	Refer to*1
oH	Main output no-operation bandwidth	0-100 Unit same as PV	2
SC	PV value amendment	-200-200 Unit same as PV	0&0.0
LCK	Date lock	(refer to*2)	0000

Note: some parameter signals maybe not showed

* 1. Relay contact output:20s, voltage impulse output or driving of gas control tube is made by trigger output or gas control tube output for 2s

* 2. Data lock grade selects

- Monitored only after data locked
- Each alarm data(HBA.LBA.LBD) can be lock under the following grades 0001.0011.0111

1. When LCK=0000 all data may be amended
2. When LCK=0001, all data may not be amended except SV, AL1,AL2
3. When LCK=0011, all data may not be amended except SV,
4. When LCK=0111, all data may not be amended

7.4 Function Setting

When the meter is energized normally, find the data lock parameter LCK according to the parameter setting mode, SET the code to 1000, then press SET key to make the meter confirm, press both SET key and R/S key at the same time for 3s, the PV display will show Cod
When Cod=0000,press SET key in turn to get the following parameters in circular display: (See Form 6)

Form6

Display symbo	Setting value	Description		
SL1	0 0 0 0	K	Thermocouple(TC)	
	0 0 0 1	J		
	0 0 1 0	R		
	0 0 1 1	S		
	0 1 0 0	B		
	0 1 0 1	E		
	0 1 1 0	N		
	0 1 1 1	T		
	1 0 0 0	PT100		RTD Input
	1 0 0 1	Cu50		
1 0 1 0	0-400Ω			
SL2	0 0 0 0	0 °C Centigrade	Selection of nominal unit	
	0 0 0 1	1 °F Fahrenheit		
	0 0 1 0	Air cooling(A type)	Selection of cooling method	
	0 0 1 1	Water cooling(W type)		
0 0 0 0	Null			
SL3	0 0 0 0	Omit		
SL4	0 0 0	No set alarm 1 function	Selection of Alarm1(ALM) type	
	0 0 1	Upper-limit bias alarm		
	0 1 0	Upper/lower-limit bias alarm		
	0 1 1	Process value upper-limit alarm		
	1 0 1	Lower-limit bias alarm		
	1 1 0	With alarm (Alarm in area)		
	1 1 1	Process value lower limit alarm		
SL5	0	No standby alarm function	Selection of alarm 1 standby functoin	
	1	With standby alarm function		
SL6	0	Forward-operation control(Cooling)	Main forward/reverse operation selection	
	1	Reverse-operation control(Heating)		
	0	Main control time scalc output		Selection of main control output type
1	Main control continuous output(4-20mA)			
SL7	0	Excitation alarming	Excitation alarming/Non-excitation alarming(Alarm 1 side)	
	1	Non-excitation alarming		
	0	Non-excitation alarming	Excitation alarming/Non-excitation alarming(Alarm 2 side)	
	1	Non-excitation alarming		
SL8	0 0 0 0	Omit		
SL9	0	Omit		
SL10	0	Non	Run/Stop function setting*2	
	1	Run/Stop function		
	0	Non	Selection of autocorrection function	
1	Autocorrection function			
SL11	0 0 0 0	Omit		

- *1. Excitation alarming means alarm relay contact changes from NO to NC. Non-excitation alarming means alarm relay contact changes from NC to NO
- *2. Run/Stop setting is effective, press "<R/S" key for about 2s, the device stop operating. PV window will display "SL10", press "<R/S" key again for about 2s, return to work.

7.5 Constant Setting

When Cod=0001,press SET key in turn to get the fo llowing parameters in circular display: (See Form 7)

Form7

Display symbol	Description	Factory value
SLH	Upper limit of setting value measurement range	*
SLL	Lower limit of setting value measurement range	*
PODP	Place number of decimal	0000
oH	Main output no-operation bandwidth	2or2.0
RH1	Alarm 1 output no-operation bandwidth	2or2.0
RH2	Alarm 2 output no-operation bandwidth	2or2.0
CTr	Current transformer ratio (For wire break alarm transformer)	*
df	Digital filter constant: range 0-100s	1sec
STFn	Time factor of stable measuring value: range 0-200s	100
STPn	Calculating factor of proportional band: range 0-200s	67
STIn	calculating factor of integration: range 0-200s	16

* according to the order

7.6 Instrument Data viewing

When Cod = 0002, all data is the recorder of meter operation, can be only seen but not amended (See Form 8)

Form8

Display symbo	Description
TCU	Maximum temperature value of instrument input terminal air
UTH	Maximum use time of instrument, min unit 10000 hours
UTL	Minimum use time of instrument ,min unit 1 hour

7.7 Failure Message Indicate

Fault information indication: When meter can't work normally, the meter diagnosed automatically to display the message prompt. (See Form 9)

Form9

Display symbo	Description
Err	Meter occurs fault
0000	The wire is disconnected at inputting, the polarity is connected inversely or above input range
0000	The wire is disconnected at inputting, the polarity is connected inversely or below input range

8. OPERATION PROCEDURES (See Fig.2 in Page 4)

9. AFTER SERVICE

The instrument is guaranteed of 18-month free maintenance or changing after the date when product leaves the factory. For product damaged by mistake operating or product with expired warranty, the maintenance will require some reasonable charge. Besides,we can give the lifelong maintenance for our products.

 About Safety Proceeding	<ol style="list-style-type: none"> 1. Before use the product, please read carefully this manual, then use it correctly on the base of understanding its content. 2. The product can be used manufacture machinery, work machinery, calculation and measurement instrument (Don't use it for the medicine machine) 3. If in the state of interruption or unusual may cause terrible system accident, please set proper protect electrical route outside, in case of the accident.
--	---

Fig.2 OPERATION PROCEDURES

