

Self-powered Time Counter

H7ET

Subminiature Time Counter Requires No External Power Supply

- Subminiature (DIN-sized 48 × 24 mm).
- Wire-wrap terminal and screw terminal types available.
- Displays cumulative time by counting the output signals received from a sensor.
- AC/DC voltage, DC voltage, and No-voltage input types available.
- Panel adapters for existing cutouts available; see Accessories section.
- Conforms to EMC standards.
- H7ET-FBV□ conforms to EN61010-1/IEC1010-1.
- Approved by UL.



Ordering Information

■ Time Counters

Operating mode		Up type				
Display		LCD digital (character height: 6.7 mm)				
Reset system		See note below				
Count input		AC/DC voltage input	DC voltage input		No-voltage input	
Terminals		Screw	Wire-wrap	Screw	Wire-wrap	Screw
Time range (Number of digits)	0.0 to 99999.9 h (6 digits: w/manual reset switch)	---	H7ET-VM	H7ET-BVM	H7ET-M	H7ET-BM
	0.0 to 999999.9 h (7 digits)	H7ET-FBV	H7ET-V	H7ET-BV	H7ET	H7ET-B
	0.0 s to 99 h 59 m 59.9 s (7 digits)	H7ET-FBV1	---	H7ET-BV1	---	H7ET-B1
	0.0 m to 9999 h 59.9 m (7 digits)	H7ET-FBV2	---	H7ET-BV2	---	H7ET-B2
	0.0 h to 3999 d 23.9 h (7 digits)	H7ET-FBV3	---	H7ET-BV3	---	H7ET-B3
Approved standards						

Note: 6-digit types (with the -M suffix) are provided with both manual and external (electric) resetting features. 7-digit types (without the -M suffix) are provided with external reset terminals.

Specifications

■ Ratings

Supply voltage		Not required (driven by built-in battery)
Input	AC/DC voltage input	High (logic) level: 24 to 240 VAC, 50/60 Hz, or 6 to 240 VDC Low (logic) level: 0 to 1.5 VAC, 50/60 Hz, or 0 to 2 VDC
	No-voltage input	Maximum short-circuit impedance: 10 kΩ max. Short-circuit residual voltage: 0.5 V max. Minimum open impedance: 500 kΩ min. Minimum pulse width: 50 ms
Reset system		External and manual reset types (6-digit models): 20 ms reset signal External reset types (7-digit models): 20 ms reset signal

■ Characteristics

Insulation resistance	100 MΩ min. (at 500 VDC)
Dielectric strength	1,000 VAC 50/60Hz for 1 minute between current-carrying terminal and exposed non-current-carrying metal parts.
Impulse withstand voltage	4.5 kV for 1 minute between current-carrying terminal and exposed non-current-carrying metal parts.
Noise immunity	Square-wave between input terminals using a noise simulator: ± 500 V.
Vibration resistance	Mechanical: 10 to 55 Hz; 0.75 mm double amplitude Malfunction: 10 to 55 Hz; 0.3 mm double amplitude
Shock resistance	Mechanical: 294 m/s ² (approx. 30 G) Malfunction: 98 m/s ² (approx. 10 G)
Ambient temperature	Operating: -10C° to 55°C (with no icing) Storage: -25C° to 65°C (with no icing)
Ambient humidity	Operating: 35% to 85%
EMC	Emission Enclosure: EN55011 Group 1 class A Emission AC Mains: EN55011 Group 1 class A Immunity ESD: EN61000-4-2: 4 kV contact discharge 8 kV air discharge Immunity RF-interference: ENV50140: 10 V/m (10 k to 1 GHz) Immunity Conducted Disturbance: ENV50141: 10 V (0.15 to 80 MHz) Immunity Burst: EN61000-4-4: 2 kV power-line 2 kV I/O signal-line
Battery life	10 years min. of continuous operation
Case color	Light gray (Munsell 5Y7/1)
Weight	AC/DC voltage input type: approx. 90 g (including mounting bracket) DC voltage & No-voltage input type: approx. 60 g (including mounting bracket)

Operation

■ Operating Modes

H7ET Time Counter

Incrementing Operation (Up)

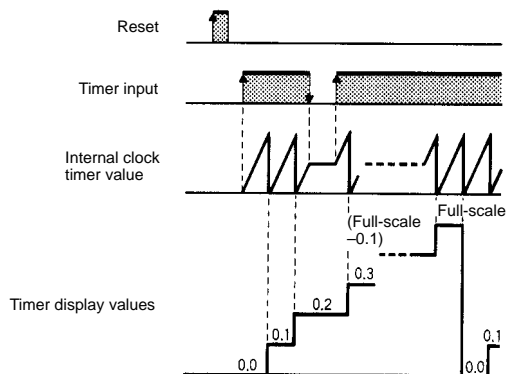

Dimensions

Wire-wrap Terminal Type

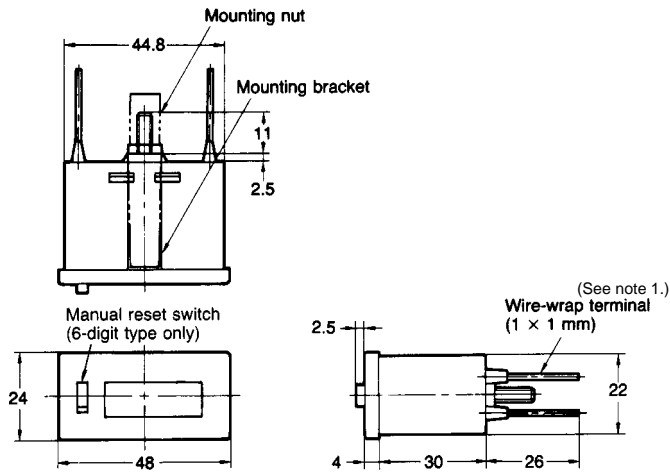

Screw Terminal Type

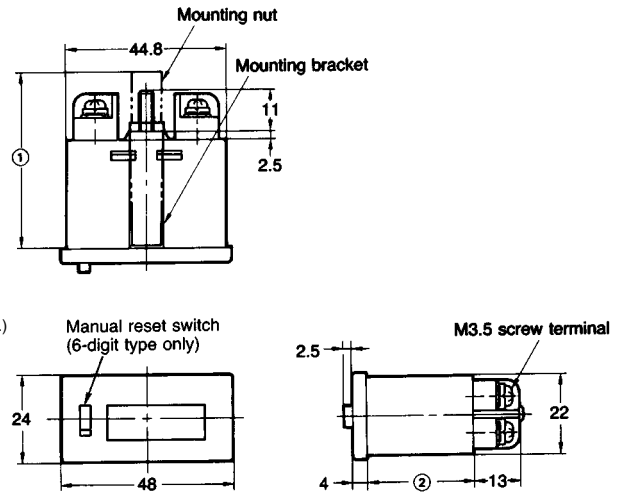

- Note:** 1. The wire-wrap terminal type can also be surface mounted.
 2. As shown in the chart below, two dimensions of the AC/DC voltage input type differ from other screw-terminal type.

Dimension	AC/DC voltage input type	DC voltage input types No-voltage input types
①	78.9	48.9
②	60	30

Panel Cutout

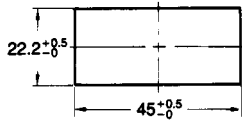

Mounting Holes

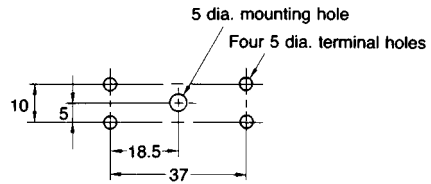

Installation

■ Connections

AC/DC Voltage Input Type

1. Contact Input (Voltage Input Through a Relay or Switch Contact)

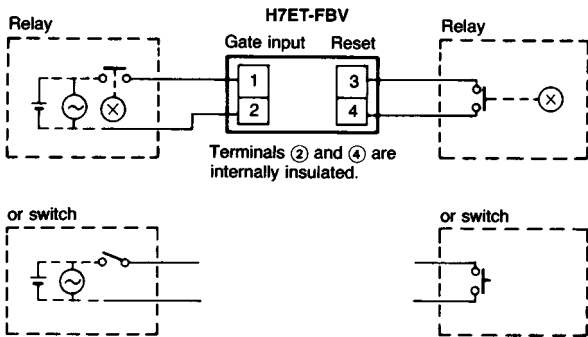

DC Voltage Input Type

Note: Select input transistors according to the following:
 Dielectric strength of the collector ≥ 50 V
 Leakage current $< 1 \mu\text{A}$

1. Contact Input (Input by a Relay or Switch Contact)

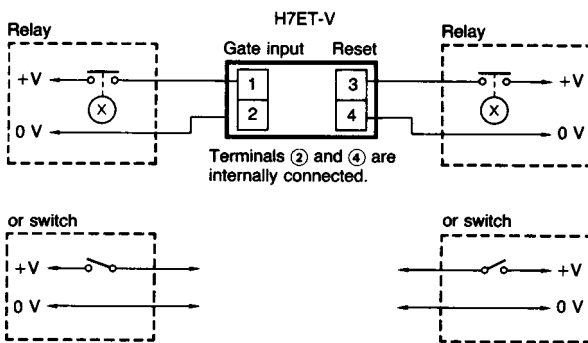

2. Solid-state Input (Open Collector Input of an NPN Transistor)

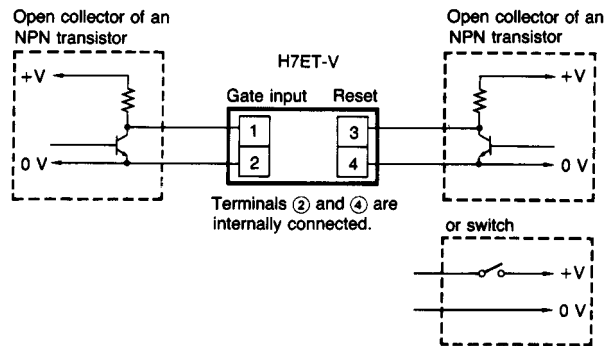

No-voltage Input Type

Note: Select input transistors according to the following:
 Dielectric strength of the collector ≥ 50 V
 Leakage current $< 1 \mu\text{A}$

1. Contact Input (Input by a Relay or Switch Contact)

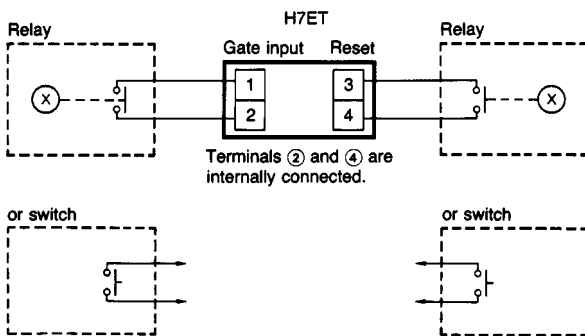

2. Solid-state Input (Open Collector Input of an NPN Transistor)

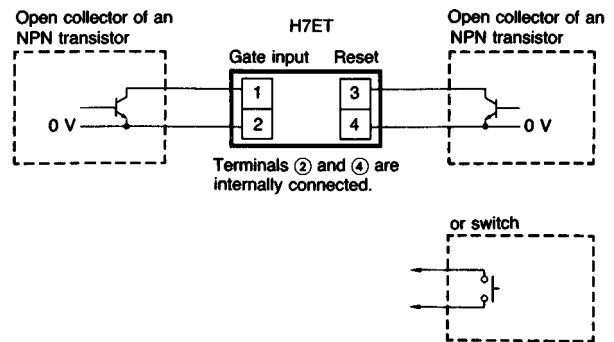

Note: Use relays and switches that have high contact reliability because the current flowing from terminals 1 or 3 is as small as approx. $10 \mu\text{A}$. It is recommended that OMRON's G3TA-IA/ID be used as an SSR.

Note: Residual voltage in the output section of proximity sensors or photoelectric sensors becomes less than 0.5 V because the current flowing from terminals 1 or 3 is as small as approx. $10 \mu\text{A}$, thus allowing easy connection.

Terminal Arrangement

Bottom View: View of the Time Counter rotated horizontally 180°

H7ET Time Counter

Standard type, non-restrictive voltage input type

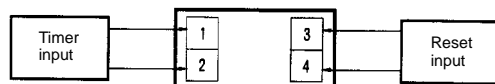

Note: Terminal 2 and terminal 4 are connected in the following manner:
 DC voltage input/No-voltage input type: Short-circuited, not insulated
 AC/DC voltage input type: Insulated

Accessories (Order Separately)

The H7ET are supplied with the mounting bracket and nut. Additionally, the panel adapters shown here allow the H7ET models to be fitted to existing panel cutouts.

Flush Mounting Adapter Y92F-75 for 26 × 45 Rectangular Cutout

Use mounting bracket supplied with the Counter

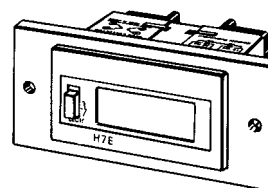
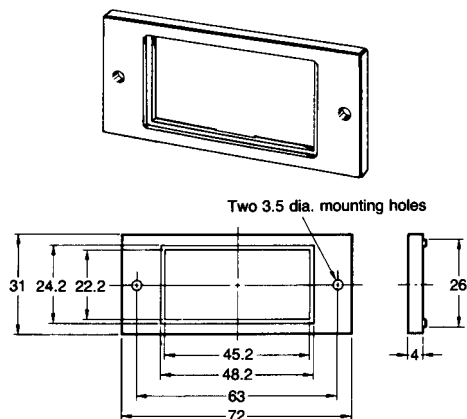

Panel Cutout

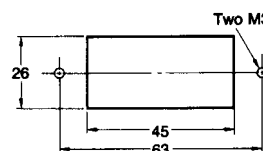

Flush Mounting Adapter Y92F-76 for 27.5 × 52.5 Rectangular Cutout

Use mounting bracket supplied with the Counter

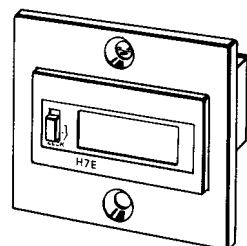
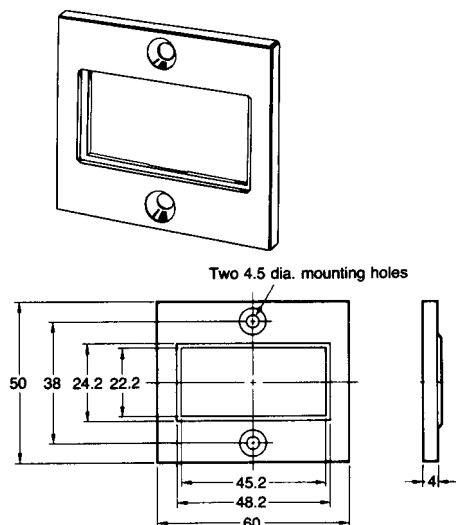

Panel cutout

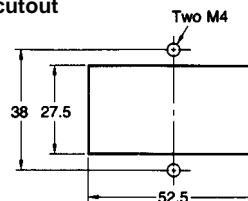

**Flush Mounting Adapter Y92F-77
for 24.8 × 48.8 Rectangular Cutout**

Note: Use the Y92F-77 Adapter with the attached No.2 Mounting Bracket. The -FBV models cannot be used.

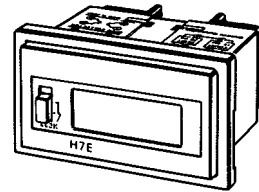
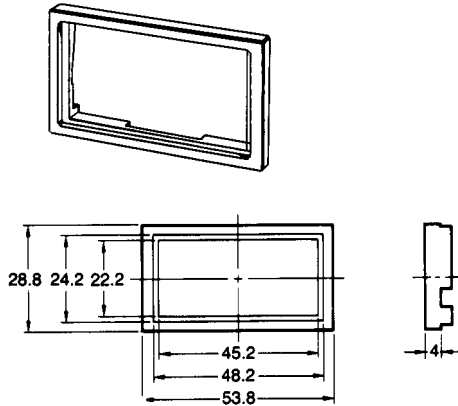

Panel Cutout

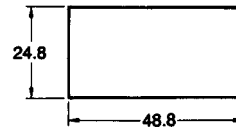

Precautions

Reset Input or Count Input to More than One H7E Counter at a Time

- No-voltage Input

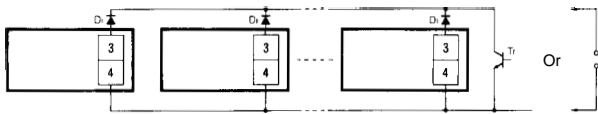

- Note:**
1. The leakage current of the transistor used for input must be less than 1 μ A.
 2. The forward voltage of the D₁ must be as low as possible (i.e., 0.1 V maximum with an I_F of 20 μ A) so that the voltage between terminals 3 and 4 will be 0.5 V when reset input is ON.

- Voltage Input

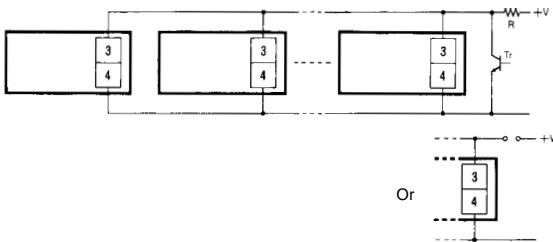

Note: H (Reset ON) level must be 4.5 V minimum.

$$H = \frac{4.7 \text{ (k}\Omega\text{)}/N + V}{4.7 \text{ (k}\Omega\text{)}/N + R}$$

Reset Input and Count Input

The H7E operates using its built-in battery. If the H7E is connected to a device that has +V and OUT terminals that are connected with a diode as shown in the circuit diagram, the circuit indicated by arrow 1 or 2 will be formed when the device is turned off. As a result, the H7E may be reset or count by one. It is recommended that such devices not be connected to the H7E.

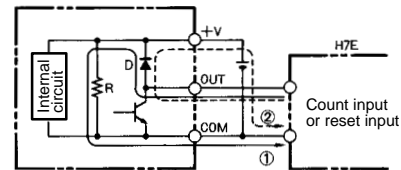

Input and Power Supply

- Do not impose voltage on the Counter if the Counter is a model that operates with no-voltage input, otherwise the internal circuit of the Counter may be damaged. Do not connect any single input signal in parallel to Counter models operating with non-voltage input and those operating with voltage input, otherwise the Counters may malfunction.
- When connecting a sensor to the Counter that operates with no-voltage input, make sure that the sensor has open collector output.

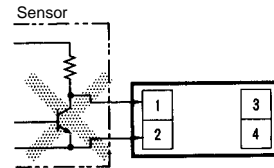

- When using shielded wire, stray capacitance may occur. The operation of the Counter might be affected when using wires which have a capacitance exceeding 500 pF (about 10 m, with parallel wires of 2 mm²). Keep all wires as short as possible.
- When connecting an open collector input from a transistor to the Counter that operates with no-voltage input, make sure that the leakage current of the transistor is 5 μ A maximum.

- When connecting count input from an SSR to the Counter that operates with free-voltage input, use OMRON's G3TA-1A or G3TA-ID SSR, otherwise make sure that the leakage current of the SSR is 0.1 mA maximum or connect a bleeder resistor in parallel to the input circuit of the Counter.

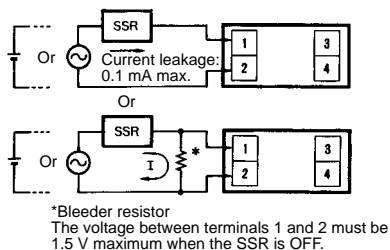

Manually Resetting Counters (-M Models)

Reset the Counter by pressing the reset button, located to the left of the display window. To prevent an accidental reset, lock the reset button by sliding the button downward, without depressing it. A small "click" sound may be heard, both when locking and unlocking the reset button. Slide the button up to unlock.

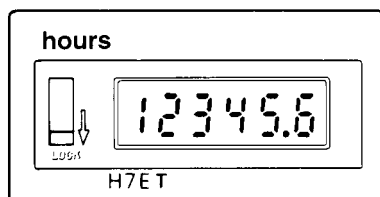

Wire-wrap Terminals

The dimensions of the terminals used on H7E wire-wrap models measure 1 × 1 mm. When wiring a Counter with wire-wrap terminals, select one of the three gauges of wire from the table below. Also listed in the table are the appropriate wiring hardware.

Wire gauge	Bit	Sleeve	Method
AWG22	2-A	2-B	Normal wire-wrap
AWG24	1-A	1-B	Normal wire-wrap
AWG26	3-A	3-B	Normal wire-wrap

How to Mount the Counter

Insert the H7E Counter from the front of the mounting panel. Slide the mounting bracket into place from the rear of the panel, and tighten the knurled nut by hand. Do not use tools (such as pliers) to tighten the nut. Excessive tightening may damage the Counter.

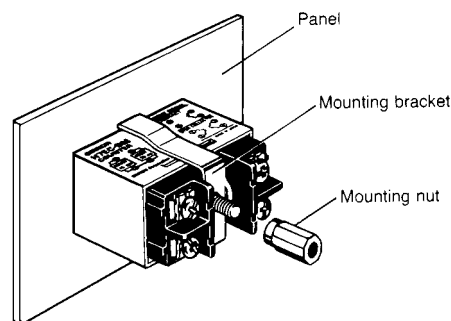

Input Verification with the H7ET Time Counter

The decimal point of the LCD blinks every other second while an input signal is being applied. If the decimal point is not blinking, the input signal is not being received correctly. Check the input signal connections.

Caution

The H7ET has a built-in lithium battery. Be sure to dispose of the old H7ET properly, as lithium batteries are likely to explode if incinerated.