

CB / CD / CH SERIES INSTRUCTION MANUAL

IMCX01-E1

Before operating this instrument, please carefully read this manual and fully understand its contents. And always keep it around you to make it available easily anytime.

WARNING

- If failure or error of this instrument could result in a critical accident of the system, install an external protection circuit to prevent such an accident.
- Do not turn on the power supply until all of the wiring is completed. Otherwise electric shock, fire or malfunction may result.
- Use this instrument within the scope of its specifications. Otherwise fire or malfunction may result.
- Do not use this instrument in the places subject to flammable or explosive gas.
- Do not touch high-voltage blocks such as power supply terminals, etc. Otherwise electric shock may result.
- Never disassemble, repair or modify the instrument. This may Cause electric shock, fire or malfunction.

CAUTION

- Only clean the instrument when power off.
- Please use a soft cloth or cotton paper to clean up the stain on the display.
- Do not clean up or touch the display by hard matters in case of any scratch.
- Never use sharp & hard matters such as screwdrivers or ball pen to touch the buttons on the panel, in case of any scratch or damage.

1. PRODUCT CHECK

Check whether the delivered product is as specified by referring to the following model code list.

CB□00
CD□01 □□□□-□□*□□-□
CH□02 ① ② ③ ④ ⑤ ⑥ ⑦ ⑧

- ① Control action
F: PID action with autotuning (Reverse action)
D: PID action with autotuning (Direct action)
W: Heat/cool PID action with autotuning (Water cooling)
A: Heat/cool PID action with autotuning (Air cooling)
- ② Input type, ③ Range code: See 8.INPUT RANGE TABLE.
- ④ First control output[OUT1](heat-side)
M: Relay output T: Triac V: Voltage pulse
8: Current (4t020mADC) G: Trigger (for triac driving)
- ⑤ Second control output[OUT2](heat-side)
No symbol: When control action is F or D. M: Relay contact
T: Triac V: Voltage pulse
- ⑥ First alarm[ALM1], ⑦ Second alarm[ALM2]
N: No alarm G: Deviation high/low alarm with hold action
A: Deviation high alarm H: Process high alarm
B: Deviation low alarm J: Process low alarm
C: Deviation high/low alarm K: Process high alarm with hold action
D: Band alarm L: Process low alarm with hold action
E: Deviation high alarm With hold action
F: Deviation low alarm With hold action
- ⑧ Communication function
N: no communication function 5: RS-485(2-wire system)

<Accessories>

- Mounting bracket: 2 pieces *1
 - Mounting screws (with hexagon nuts): 2 pieces *1
 - Instruction manual [IMCX01-E1](1 copy)
- *1CB100, CD101, CH102 Mounting bracket: 1 pieces

2. MOUNTING

2.1 Mounting cautions

- (1) This instrument is intended to be used under the following environmental conditions. (Iec1010)
*OVERVOLTAGE CATEGORY II *POLLUTION DEGREE-2
- (2) Avoid the following when selecting the mounting location.
 - Ambient temperature of less than 0°C or more than 50°C.
 - Ambient humidity of less than 45% or more than 85%RH.
 - Rapid changes in ambient temperature which may cause condensation.
 - Corrosive or inflammable gases.
 - Direct vibration or shock to the mainframe.
 - Water, oil, chemicals, vapor or steam splashes.
 - Excessive dust, salt or iron particles.
 - Excessive induction noise, static electricity, magnetic fields or noise.
 - Direct air flow from an air conditioner.
 - Should be used in doors where the system is not exposed to direct sunlight.
 - Heat to be accumulated radiation heat

2.2 Dimensions

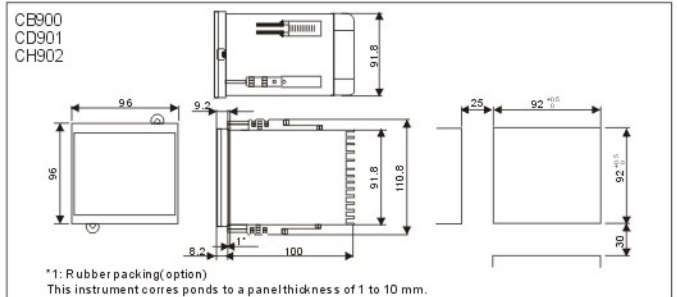
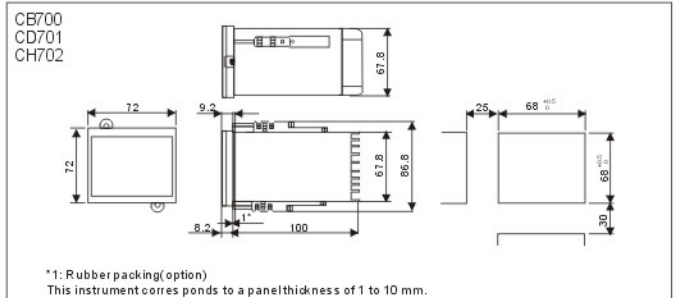
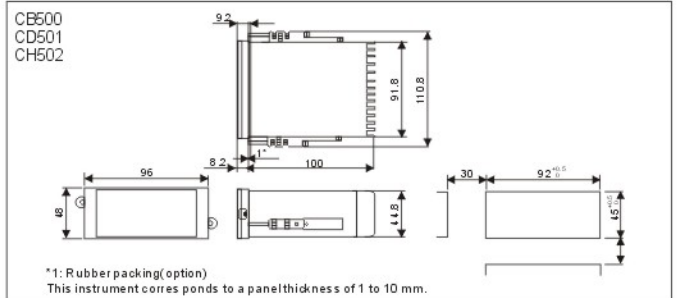
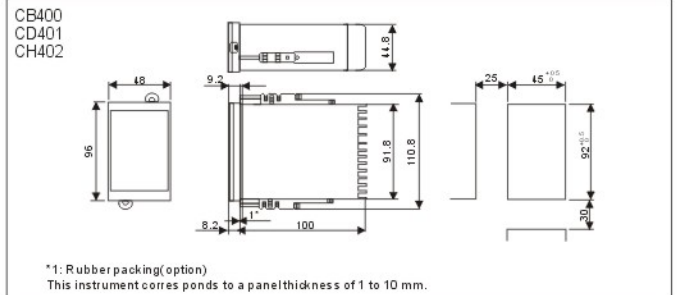
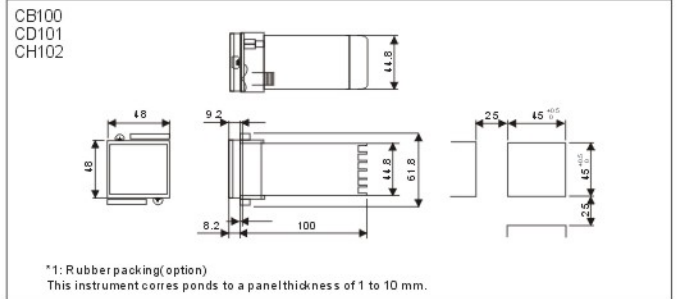

3. WRING

3.1 Wiring cautions

- (1) For thermocouple input, use the specified compensation wire.
- (2) For RTD input, use low resistance and having no resistance differences among the 3 leads.
- (3) Conduct input signal wiring away from instrument power, electric equipment power and load lines to avoid noise induction.
- (4) Conduct instrument power wiring so as not to be influenced by noise from the electric equipment power. If the instrument may be affected by external noise, a noise filter should be used.

- reduce the distance of power source wire
- install the filter at controller's panel, then into earth.
- don't set the protection and switch at the output side of filter.

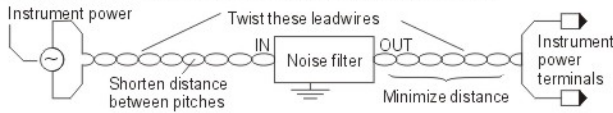

3.2 Terminal configuration

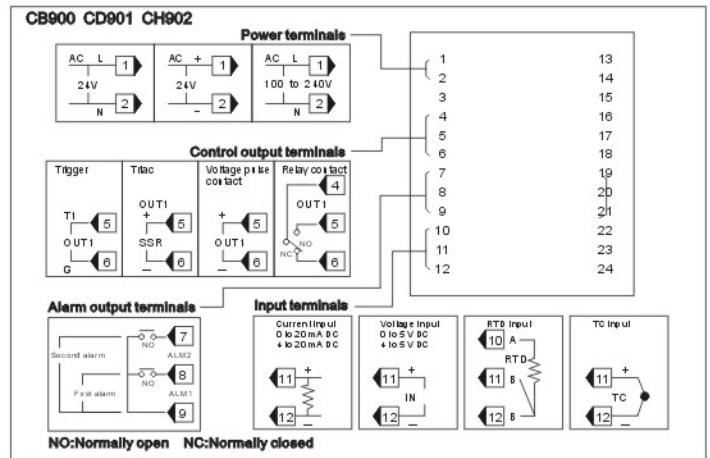
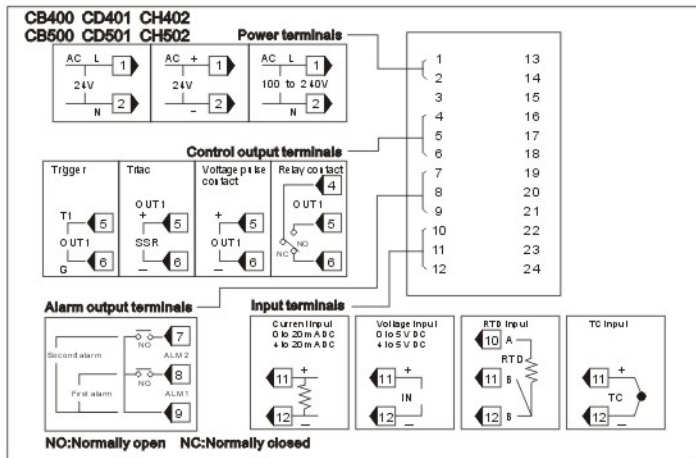
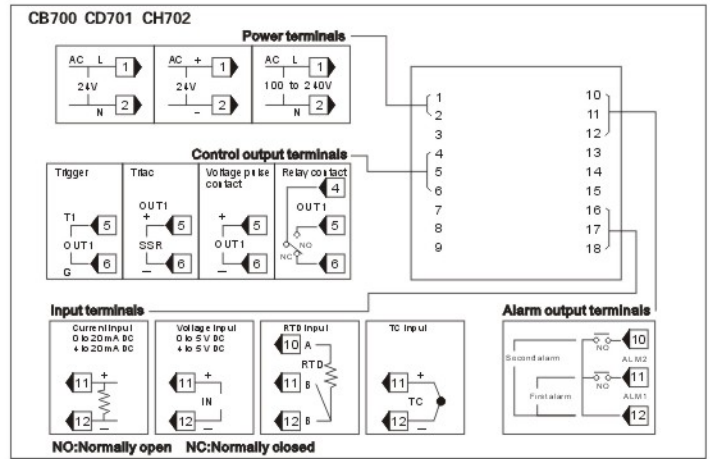
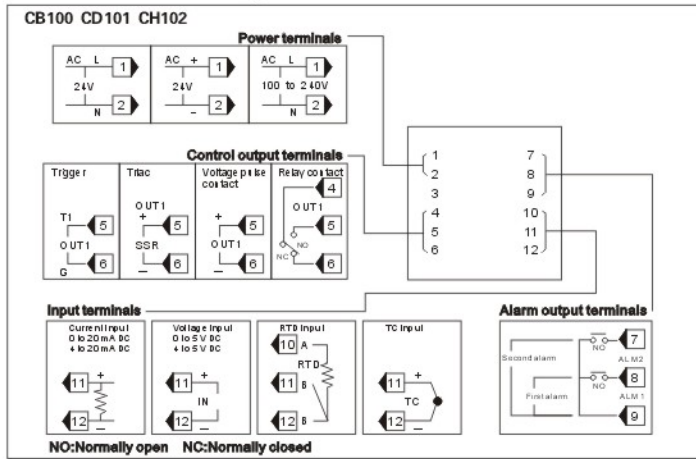

Power supply voltage:

- 90 to 264 VAC (Including power supply voltage variation)
- (Power frequency: 50/60 Hz, Rating: 100 to 240 V AC)
- 21.6 to 26.3 V AC (Power frequency: 50/60 Hz, Rating: 24 V AC)
- 21.6 to 26.2 V DC (Rating: 24 V DC)

Power consumption: 7VA max. (at 100 VAC) 10 VA max. (at 240 VAC)

Alarm output rated: Relay contact output: 250 V AC, 1A (Resistive load)

Control output rated:

- Relay contact output: 250 V AC, 3A (Resistive load)
- Voltage pulse output: 0/12 V DC (Load resistance 600 Ω or more)
- Current output: 4 to 20 mA DC (Load resistance 600 Ω or less)
- Trigger output (for triac driving): Zero cross method for medium capacity triac driving (100 A or less)
- Triac output: 0.5 A (Ambient temperature 40°C or less)

4. NAME OF PARTS

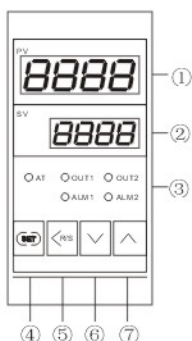

① Measured value (PV) display unit [Green]

- Displays measured value (PV).
- Displays various parameter symbols depending on the instrument.

② Set value (SV) display unit [Orange]

- Displays set value (SV).
- Displays various parameter set value depending on the instrument.

③ Indication lamps**

- Autotuning (AT) lamp [Green]
- Flashes during autotuning execution.

Control output lamp (OUT1) [Green]

Lights when control output is turned on.

Alarm output lamp (ALM1) [Red]

Lights when alarm output is turned on.

**No OUT2 lamp is used.

- ④ **Set key (SET)**
Used for parameter registration /calling up.

⑤ Shift & R/S KEY <R/S

- Used to shift the digit when the setting is changed. (Shift Key).
- Used to select the RUN/STOP Function. (R/S key).

- ⑥ **DOWN key** ▽
Used to decrease numerals.

- ⑦ **UP key** ▲
Used to increase numerals.

5. SETTING

5.1 Calling up procedure of each mode

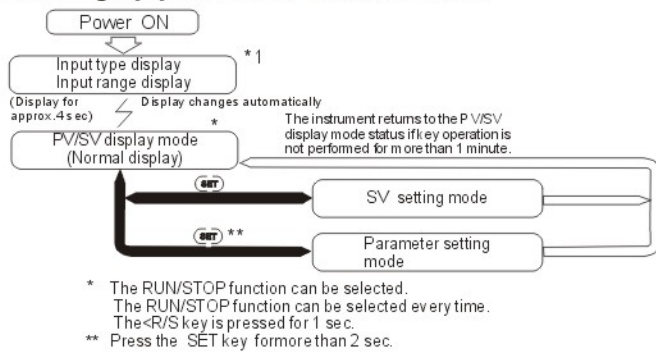

*1. Input type and input range display

This instrument immediately confirms input type and range following power on. Example: For a controller with the K thermocouple input type and range from 0 to 1372°C.

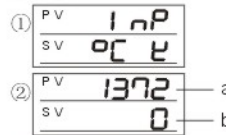

- ① Input type display
 n P : Indicates input abbreviation
 C : Indicates engineering unit
 e : Indicates input type (See table **A)
- ② Input range display
 a : Input range high
 b : Input range low

**A: Input type table

Display	E	J	R	S	B	E	T	N	P	W5Re/	W26Re	U	L	JPT	PT	V
Input type	Thermocouple(TC)											RTD		Voltage (Current)		

5.2 Detail of each mode

■ PV/SV display mode

Display measured value (PV) on the PV display unit and set value (SV) on the SV display unit. Usually the control is set to this mode excepting that the Set value (SV) and/or the parameter set value are changed. In addition, in this mode, RUN/STOP can be selected.

■ SV setting mode

This is the mode used to set the set value (SV). Factory set value: 0.0°C or 0.0°C

■ Parameter setting mode

This is the mode used to set various parameters such as alarms, PID constants, etc. The following parameter symbols are displayed one by one every time the SET key is pressed.

#1 Factory set value

Symbol	Name	Setting range	Description	#1
AL1	Alarm(ALM1)	Deviation alarm, Process alarm, SV alarm: -1999 to +1999°C or -199.9 to +999.9°C	Set the alarm set value. Alarm differential gap: 2 or 2.0°C	50 (50.0)
AL2	Alarm(ALM2)	Deviation alarm, Process alarm, SV alarm: -1999 to +1999°C or -199.9 to +999.9°C	Set the alarm set value. Alarm differential gap: 2 or 2.0°C	50 (50.0)
ATU	Autotuning(AT)	0: AT end or AT suspension 1: AT start	Turns the autotuning ON/OFF.	0
STU	Self-tuning(ST)	0: ST suspension 1: AT start	Turns the self-tuning ON/OFF.	0
P	Proportional band(P)	1 (0.1) to span or 9999 (999.9) %	Set when PI, PD or PID control is performed. *ON/OFF action control when set to 0 (0.0). Differential gap: 2 (0.0) %	30 (30.0)
I	Integral time (I)	1 to 3600 sec *PD control when set to 0 sec	Set the time of integral action which eliminates the offset occurring in proportional control.	240
D	Derivative time(D)	1 to 3600 sec *PI control when set to 0 sec	Set the time of derivative action which prevents ripples by predicting output changes and thus improves control stability.	60
Ar	Reference value(Ar)	0 to 100 % *1	After AT, set automatical.	25
T	Heat-reset Proportioning cycle(T)	1 to 100 sec (0 can not be set) *2	Set control output cycle.	20
Pc	Cool-side proportional band(Pc)	1 to 1000 % of heat-side proportional band (0 can not be set)	Set cool-side proportional band when heat/cool PID action.	100
db	Deadband (db)	Temperature input: -10 to +10 °C or -10.0 to +10.0 °C	Set control action deadband between heat-side and cool-side proportional bands.	0 or 0.0
t	Cool-side Proportioning cycle(t)	1 to 100 sec (0 can not be set) *2	Set control cool-side output cycle for heat/cool PID action.	20
Pb	PV bias (Pb)	-1999 to +9999°C or -199.9 to +999.9°C	Sensor correction is made by adding bias value to measured value (PV).	0 or 0.0
LCK	Set data lock function (LCK)	See *3	Performs set data change enable/disable.	0000

*1: The reference value can't be manually set within PID, after "AT" autotuning, set the value automatical.

*2: Relay contact output 20 sec the voltage pulse output/valve control the tube by Trigger output/the valve control the tube output for 2 sec on.

*3: Details of set data lock level selection

Setting	Details of lock levels
0000	SV and parameter can be set.
0001	Only SV and alarm (ALM1, ALM2) can be set.
0010	Only setting items other than alarms (ALM1, ALM2) can be set.
0011	Only setting items other than SV can be set.
0100	Only SV can set.
0101	Only alarms (ALM1, ALM2) can be set.
0110	Only setting items other than SV and alarms (ALM1, ALM2) can be set.
0111	SV and parameter cannot be set.

● Each locked setting item can only be monitored.

6. OPERATIONS

6.1 Operation procedures

CAUTIONS

- Connect the input signal wiring, and then turn on the power. If the input signal wiring opens, the instrument judges the input is disconnected.
 - + Upscale *1 : TC input, RTD input (Downscale when the input is shorted)
 - + Downscale *1 : TC input (To be specified when ordering), Voltage input (Current input) *2
 - *1 : Alarm output ON (However, for the W or A control action type, the control output on both heat-side and cool-side is turned off.)
 - *2 : For 0 to 5VDC or 0 to 20 mADC, both control and alarm outputs are indefinite
- No influence is exerted upon the instrument for power failure of 20 ms or less. For power failure of more than 20 ms, the instrument performs the same operation as that at the time of power on after power recovery (This applies only when alarm action is turned off).
- The alarm hold action is activated when not only the power is turned on, but also the SV is changed.

- (1) Prior to starting operation, check that the mounting and wiring have been finished, and that the SV and various parameters have been set.
- (2) As this instrument does not have a power supply switch, it is ready to operate as soon as the power is turned on. Prior to factory shipment, the instrument is set to RUN (operation start).

NOTES

- If the instrument is switched to operation stop (STOP), its display output, etc. become as follows.
 - Display: The PV display unit shows **STOP** (STOP).
 - Output: Control output OFF, Alarm output OFF
- Suspended when the AT function is activated. (The PID constants are not updated.)
- This instrument holds the conditions that exist just before the power is turned on. For example, if the power is turned off in STOP mode, the instrument starts in STOP mode when the power is turned on again.

6.2 Set data lock (LOCK) function

The set data lock function is used to prevent misoperation by not setting any parameter which is not used frequently. There are 8 set data lock levels, and the parameter is locked, but can only be monitored.

6.2 Autotuning (AT) function

The AT function automatically measures, computes and sets the optimum PID and Ibc constants. This function is activated after-CN, during temperature rise and/or when control is stabilized from any process state.

■ Requirements for AT start

Start AT when all the following conditions are satisfied:

- Prior to starting the AT function, end all the parameter settings other than PID and Iba.
- Confirm the LCK function has not been engaged.

■ Requirements for AT suspension

Start AT function is suspended if any of any the following conditions is established:

- When the SV is changed.
- When the PV bias value is changed.
- When the SVRUN/STOP function is changed to the STOP.
- When the PV becomes abnormal. (According to the burnout.)
- When the power is turned on.
- When a power failure longer than 20 ms occurs.
- When the AT function does not end in about 9 hours after tuning started.

NOTES

- If the AT suspension condition is established, the AT function is immediately suspended to be changed to PID control. The PID and Iba constants at this time are the same as before starting AT. In addition, even if the AT is completed, it is automatically transferred to PID control.
- If any problems arise due to hunting exists in the control system, do not use the AT function. In this case, set each value to match the controlled object.

7. DISPLAY AT ERROR OCCURRENCE

■ Error display

Err	RAM failure (Incorrect set data write, etc.)	Please contact us or your nearest RKC agent.
------------	---	--

■ Overscale and Underscale

0000 (Flashing)	Measured value (PV) exceeds the input range.	 WARNING In order to prevent electric shock, prior to replacing the sensor, always turn off the power. Sensor input lead check.
UUUU (Flashing)	Overscale Measured value (PV) exceeds the high input display range limit.	
UUUU (Flashing)	Underscale Measured value (PV) exceeds the low input display range limit.	

8. INPUT RANGE TABLE

	Input type	Comde		Input type	Comde		Input type	Comde		
K	0 to 200 °C	K 01	S	*1 0 to 1600 °C	S 01	Pt100	-199.9 to +649.0 °C	D 01		
	0 to 400 °C	K 02		*1 0 to 1769 °C	S 02		-199.9 to +200.0 °C	D 02	-1999 to 9999	
	0 to 600 °C	K 03		*1 0 to 1800 °C	B 01		-100.0 to +50.0 °C	D 03		4 01
	0 to 800 °C	K 04		*1 0 to 1820 °C	B 02		-100.0 to +100.0 °C	D 04		5 01
	0 to 1000 °C	K 05		0 to 1800 °C	E 01		-100.0 to +200.0 °C	D 05		6 01
	0 to 1200 °C	K 06		0 to 1000 °C	E 02		0.0 to 50.0 °C	D 06		7 01
	0 to 1372 °C	K 07		0 to 1200 °C	N 01		0.0 to 1000 °C	D 07		
	0 to 100 °C	K 13		0 to 1300 °C	N 01		0.0 to 200.0 °C	D 08		
	0 to 200 °C	K 14		*2 -199.9 to +400.0 °C	T 01		0.0 to 300.0 °C	D 09		
	0 to 450 °C	K 17		*2 -199.9 to +100.0 °C	T 02		0.0 to 500.0 °C	D 10		
0 to 500 °C	K 20	0.0 to 350.0 °C	T 03	0.0 to 400.0 °C	D 20					
J	0 to 200 °C	J 01	T	-100.0 to +200.0 °C	T 04	JPT100	-199.9 to +649.0 °C	P 01		
	0 to 400 °C	J 02		W5Re/	0 to 2000 °C		W 01	-199.9 to +200.0 °C	P 02	
	0 to 600 °C	J 03		W26Re	0 to 2320 °C		W 02	-100.0 to +50.0 °C	P 03	
	0 to 800 °C	J 04		PLII	0 to 1800 °C		A 01	-100.0 to +100.0 °C	P 04	
	0 to 1000 °C	J 05			0 to 1390 °C		A 02	-100.0 to +200.0 °C	P 05	
	0 to 1200 °C	J 06			0 to 1200 °C		A 03	0.0 to 50.0 °C	P 06	
0 to 450 °C	J 10	U	*2 -199.9 to +600.0 °C	U 01	0.0 to 100.0 °C	P 07				
0 to 500 °C	J 20		*2 -199.9 to +100.0 °C	U 02	0.0 to 200.0 °C	P 08				
R	*1 0 to 1600 °C	R 01	L	0.0 to 400.0 °C	U 03	0.0 to 300.0 °C	P 09			
	*1 0 to 1700 °C	R 02		0 to 400 °C	L 01	0.0 to 500.0 °C	P 10			
	*1 0 to 1350 °C	R 04		0 to 800 °C	L 02	0.0 to 400.0 °C	P 20			

*1 0 to 399 °C : Accuracy is guaranteed.

*2 -199.9 to -100.0 °C : Accuracy is not guaranteed.